

WELL INTERVENTION | HYDRAULIC WORKOVER

SafeGrip® pipe control system

The Halliburton patented SafeGrip® system ensures that both slip bowls in a pair are completely closed and hydraulically pressured before the system allows the other pair of slip bowls to open. The interlocking is achieved using sensors mounted onto each pair of slip bowls. Both pressure and slip position sensors must be tripped to open the interlock.

Because there is always at least one heavy slip bowl and one snubbing slip bowl engaged on the pipe at all times the pipe is always restrained from dropping or ejection.

The SafeGrip® system is designed to always fail-safe. It is a fully hydraulic logic system with no electrical components to help assure maximum reliability and service life.

How the SafeGrip® system works

Snubbing units are typically equipped with 4 slip bowls per unit – a pair of traveling slip bowls and a pair of stationary slips. Each pair of slips has one (heavy) bowl to handle pipe heavy and one (snubbing) bowl to handle pipe light. These units are equipped with one SafeGrip® system.

During all operations – the active pair of slip bowls (either traveling or stationary) are interlocked (i.e. one pair of slip bowls must be closed on the pipe at all times).

It is important to note that the SafeGrip® system does not prevent the operator from closing any pair of slip bowls at any time. The operator can close the slip bowls without restriction at any time as warranted. The SafeGrip® system only prevents the opening of one pair of slip bowls without the other pair of slip bowls being closed on the pipe first.

Override controls and functionality

There is one override control which, when activated, allows both pairs of slips to be opened simultaneously. The override control is located on an override control panel that is located on a stand on the ground. Only supervisors are authorized to operate the override control.

Once an overridden pair of slip bowls is actuated closed, the override mode is automatically terminated, and both slip bowls will automatically operate again in interlock mode thereafter until the override is applied again.



SafeGrip® addresses the following load control risks:

- Operator error - accidentally opening a set of closed slips against pipe weight (load) when working in the balance point zone
- Load reversal – pipe suddenly becoming light or heavy due to well conditions
- Failure of the slip bowl to fully close on pipe due to mechanical or hydraulic fault, or buckling of pipe
- Loss or reduced slip bowl hydraulic pressure

When override is typically needed

The override control will only be needed in two phases of the job: At the beginning of the job both traveling and stationary slip bowls will require override to open lower the BHA into the BOP stack before the well is opened. Again, at the end of the intervention, to remove the BHA from the unit, both the traveling and stationary slips (both pair) are opened via override actuation, after the wellbore is shut in and BOPs are bled off.

Safety improvements, such as SafeGrip®, incorporate equipment designs to address risks, as opposed to relying on process/procedural-type solutions that require 100% human compliance to be effective. Such systems promote operational efficiency by helping prevent service-quality incidents and potential health, safety, and environment (HSE) events.

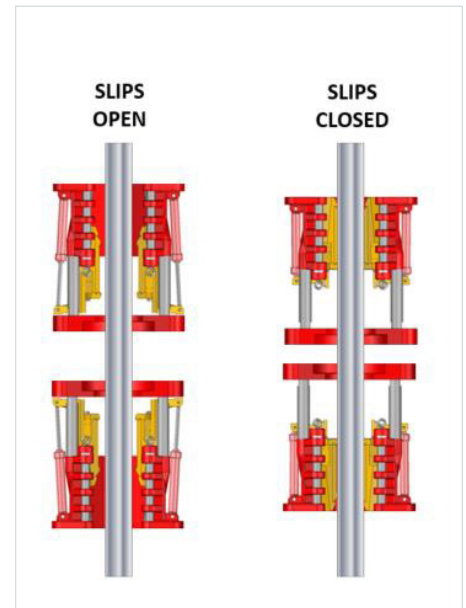
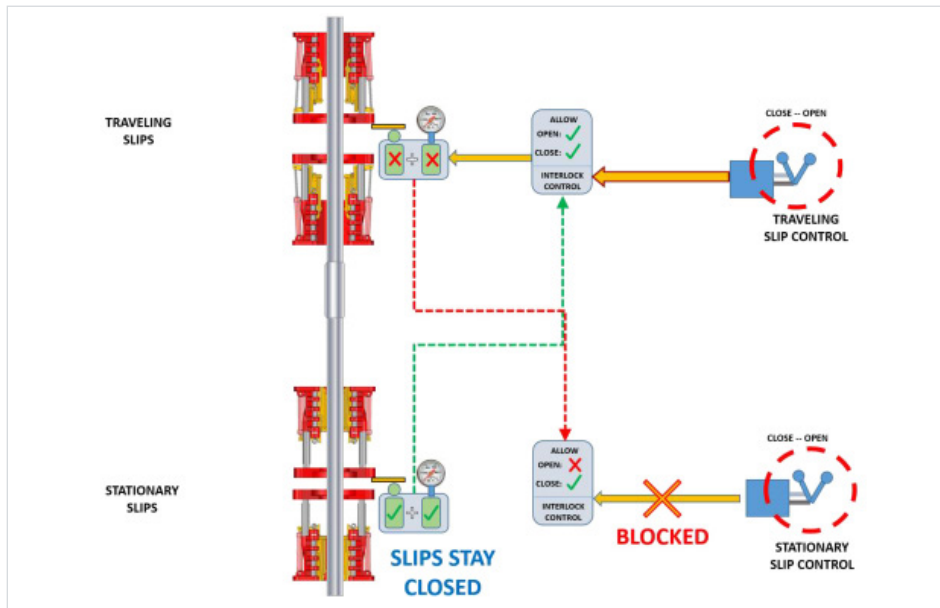

SafeGrip® function diagram

For more information, contact your local Halliburton representative or visit us on the web at www.halliburton.com

Sales of Halliburton products and services will be in accord solely with the terms and conditions contained in the contract between Halliburton and the customer that is applicable to the sale.

H014854 10/24 © 2024 Halliburton. All Rights Reserved.